



## INSTRUCTION MANUAL

**MT476**

**690V VOLTAGE TESTER**





## Contents

## Page no

1. Safety Warnings.....	4
1.1. International Safety Warnings.....	4
1.2. Safety Notes.....	4
1.3. Data Hold Button.....	4
1.4. Warnings.....	5
2. Specifications.....	7
3. Voltage Tester Description.....	8
4. Explanation of Symbols.....	9
5. Inserting/Changing the Batteries.....	9
6. Measuring Point Lighting.....	9
7. Carrying Out Measurements.....	10
8. Voltage Measurement with Low Internal Impedance.....	10
9. Rotating Field Direction Display.....	11
10. Continuity Check.....	12
11. Using the Tester as a "Single Phase" Tester.....	12
12. Maintenance and Disposal.....	13
13. Disposal of Batteries and rechargeable Batteries.....	13

## 1. SAFETY WARNINGS

### 1.1. International Safety Symbols



Warning of a potential danger, comply with instruction manual.



Caution! Dangerous voltage. Danger of electrical shock.



Double insulation.

### 1.2. Safety Notes

- Reference. Please use utmost attention.
- Do not exceed the maximum allowable input range of any function
- Be sure to read the instructions carefully before using and check that the battery is adequate. Do not remove the voltage detector without authorization from professional technicians. If the voltage detector is not used for a long time, take out the battery and store it in a dry tool box.

### 1.3. Safety Advices

- Depending on the internal impedance of the voltage detector there will be a different capability of indicating the presence or absence of operating voltage in case of the presence of interference voltage.
- A voltage detector of relatively low internal impedance, compared to the reference value of  $100\text{k}\Omega$ , will not indicate all interference voltages having an original voltage value above the ELV level. When in contact with the parts to be tested, the voltage detector may discharge temporarily the interference voltage to a level below the ELV, but it will be back to the original value when the voltage detector is removed.
- When the indication "voltage present" does not appear, it is highly recommended installing earthing equipment before work.
- A voltage detector of relatively high internal impedance, compared to the reference value of  $100\text{k}\Omega$ , may not permit to clearly indicate the absence of operating voltage in case of presence of interference voltage.
- When the indication "voltage present" appears on a part that is expected to be disconnected of the installation, it is highly recommended confirming by another means (e.g. use of an adequate voltage detector, visual check of the disconnecting point of the electric circuit, etc.) that there is no operating voltage on the part to be tested and to conclude that the voltage indicated by the voltage detector is an interference voltage.
- A voltage detector declaring two values of internal impedance has passed a performance test of managing interference voltages and is (within

technical limits) able to distinguish operating voltage from interference voltage and has a means to directly or indirectly indicate which type of voltage is present.

#### 1.4. Warnings

- ⚠ The voltage detectors are designed to be used by skilled persons and in accordance with safe methods of work. The hand should not exceed the stop position when operating. Do not contact exposed wires or connectors.
- ⚠ In order to avoid electrical shock, the valid safety and VOE regulations regarding excessive contact voltages must receive utmost attention, when working with voltages exceeding 120V (60V) DC or 50V (25V) RMS AC. The values in brackets are valid for limited ranges (as for example medicine and agriculture).
- ⚠ Prior to measurement ensure that the test leads and the test instrument are in perfect condition.
- ⚠ When using this instrument only the handles of the probes may be touched - do not touch the probe tips.
- ⚠ This instrument may only be used within the ranges specified and within low voltage systems up to 690V.
- ⚠ Prior to usage ensure perfect instrument function (e.g. on known voltage source).
- ⚠ The voltage testers may no longer be used if one or several functions fail or if no functionality is indicated.
- ⚠ Do not use this instrument under damp conditions.
- ⚠ Perfect display is only guaranteed within a temperature range of -10°C up to +55°C, at relative humidity question <85%.
- ⚠ If the operator's safety cannot be guaranteed, the instrument must be removed from service and protected against use.

#### **The safety can no longer be insured if the instrument:**

- Shows obvious damage
- Does not carry out the desired measurements
- Has been stored for too long under unfavorable conditions
- Has been subjected to mechanical stress during transport.
- All relevant statutory regulations must be adhered to when using this instrument.

#### **Safety issues that require attention when using:**

In order to avoid personal injury, shock or fire, special attention should be paid to:

- Please make sure the test pen before test and test equipment is in good condition
- When using the device, the hand can only contact the handle part.

- The equipment shall be in the specified range (see technical specifications) and voltage does not exceed the range of 690V.
- Ensure the function of the equipment in good condition before use.
- To ensure that the tester is normal operation, please measure a known voltage value.
- When one or a few or no function failure function indicators, the tester cannot be used again.
- Don't test in damp conditions.
- If the safety of the operator cannot guarantee, the instrument must be fixed.

If the following situations occur, security is no longer guaranteed:

#### **Appropriate Usage**

The instrument may only be used under those conditions and for those purposes for which it was designed. For this reason, in particular the safety references, the technical data including environmental conditions and the usage in dry environments must be followed.

When modifying or changing the instrument, the operational safety is no longer ensured. The instrument may only be opened by an authorized service technician, e.g. for repair.

## 2. SPECIFICATIONS

Function	Range
LCD display	1999 counts (3 1/2 digit) LCD display with bargraph & backlight
Voltage range	6, 12, 24, 50, 120, 230, 400, 690V AC/DC
Resolution	1V AC/DC
Tolerances	DCV: + 1.0% of reading +3 digit ACV: + 1.5% of reading +5 digit
400VAC Max. measuring current	approx. $\leq 1.0\text{mA}$
690VDC Max. measuring current	approx. $\leq 1.5\text{mA}$
Voltage Detection	automatic
Polarity Detection	full range
Range Detection	automatic
Response Time	< 500ms, 2 - 3 times/sec.
Operation Time	30sec.
Recovery Time	240sec.
ACV Frequency Range	50/60Hz
Internal Impedance	600K $\Omega$ /5k $\Omega$ @ELV a.c.
LCD On	>4. 5V AC/DC
<b>Single-pole Phase Test</b>	
Voltage range	100-400V AC
ACV Frequency range	50/60Hz
<b>Continuity Test</b>	
Resistance range	<400k $\Omega$
Test current	5 $\mu\text{A}$
Overvoltage protection	400V AC/DC, 690V DC
<b>Rotary Field Indication</b>	
Voltage range (LEDs)	100-400V
Frequency range	50/60Hz
Measurement principle	Double-pole and contact electrode
<b>Low impedance test</b>	
Voltage range	12-230V AC/DC
Low impedance	<6k $\Omega$
Operation time	5s<250V AC/DC, $I_s \leq 0.2\text{A}(690\text{V})/30\text{s}$ max.
Overvoltage protection	3s<400V AC/690V DC
Power supply	2 x 1.5V "AAA" Batteries
Power consumption	Max.30mA / approx. 250mW
Temperature range	-10°C up to +55°C
Humidity	Max. 85% relative humidity
Overvoltage class	CAT III 1000V CAT IV 600V

### 3. VOLTAGE TESTER DESCRIPTION



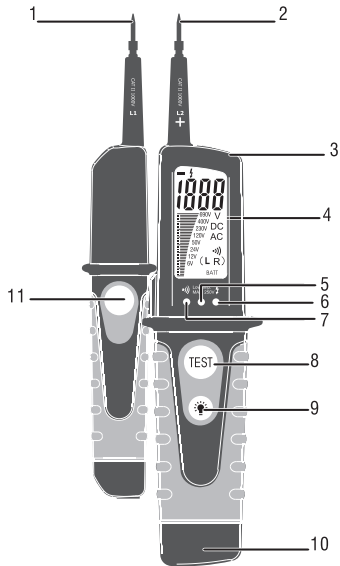



- |                                     |                                 |
|-------------------------------------|---------------------------------|
| 1 - Handle test probe - (L1)        | 8 - LED for continuity          |
| 2 - Instrument test probe + (L2)    | 9 - Low impedance switch (L2)   |
| 3 - Measurement point illumination  | 10 - Measurement point lighting |
| 4 - LEDs for voltage display        | Button                          |
| 5 - LED for single-pole phase test  | 11 - Battery case               |
| 6 - LED for low impedance test      | 12 - Low impedance switch (L1)  |
| 7 - LED for left/right rotary field |                                 |





#### 4. EXPLANATION OF SYMBOLS

The voltage tester shows the following symbols:

DC	DC voltage
AC	AC voltage
—	DC voltage negative potential (DC)
	Phase display from 100 to 690V - 50/60Hz
	when used as a "single-pole" phase tester. Continuity test symbol
	Rotating field display clockwise
	Rotating field display anticlockwise
	Device for work to be performed with voltage present
	Battery replacement symbol

#### 5. INSERTING/CHANGING THE BATTERIES

The voltage tester is operated with two micro-batteries (type AAA, in the scope of delivery).

Proceed as follows to insert or change the batteries:

- Loosen the screw on the battery compartment lid (10) with a suitable screw driver and remove it.
- Insert two batteries (AAA) into the battery compartment. Observe the polarity information in the battery compartment. If possible, use alkaline batteries. They guarantee a longer service life. Then, carefully close and screw down the battery compartment lid again. The batteries need to be changed if the "Low Bat " symbol lights up on the LCD display or when the LCD display stays dark after contacting both test tips.

-  The voltage tester will show no reading if the batteries are flat. The device must not be operated with flat batteries or without batteries. To prevent damage to the device from leaking batteries, remove the batteries from the device if you will not be using it for a longer period. For the same reason, we recommend that you remove flat batteries immediately.

#### 6. MEASURING POINT LIGHTING

The voltage tester has a battery-operated measuring point lamp. Press button (9) to switch this lamp on. The lamp stays on as long as this button is kept pressed. When the button is released, the lamp goes off. The lighting button is arranged in such a way that it can also be pressed during low impedance measurements.

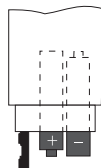

## 7. CARRYING OUT MEASUREMENTS

The twin-pole voltage tester has two handles, a connecting cable and an LCD display. Always hold the voltage tester in such a way that you get a vertical view of the display. Strong incidence of light may have an adverse effect on the display. For DC measurements, test tip is the positive pole, and the test tip is the negative pole.

⚠ Before each voltage measurement, check that the device is working properly by measuring a known voltage source. If the tester's LCD display remains blank, take the voltage tester out of operation. A defective voltage tester must not be used. Do not operate the device with flat batteries or without batteries. Observe the regulations regarding work with electrical systems.

### **The device can be used for the following types of measurement: Voltage measurement with high internal impedance**

Always hold the voltage tester by the handles designed for this purpose. Never touch the device beyond the handle ends. Hold the two test tips onto the measuring points to be tested. The voltage tester switches on automatically with voltages higher than 4.5V AC/DC. The voltage measured is shown on the LCD display. If the measured voltage falls below 4.5 V AC/DC, the voltage tester switches off automatically. The LCD display shows the voltage values numerically and in the form of a bargraph. The type of voltage (alternating current = AC or direct voltage = DC) and the polarity are also shown on the LCD display. In the event of negative DC voltage, the numeric voltage value is preceded by "-". Positive DC voltage is shown without a positive sign preceding the value.

⚠ Thanks to the input impedance of approx. 600K $\Omega$ , it is possible to perform voltage tests with high input impedances without time restrictions. The voltage tester also indicates a rotating direction (L or R) with measurements on single-phase mains (L1 against N). This is not a device malfunction.

### **8. VOLTAGE MEASUREMENT WITH LOW INTERNAL IMPEDANCE**

This function is particularly useful for testing installations. Due to the lowered internal impedance, capacitive voltage is suppressed. The reading shows the actual voltage applied. Similarly, measuring phase (L1) on earth wire (PE) may trigger fault-current circuit breakers (FI or RGI). This measuring procedure can be used for measurements above 12V. Always hold the voltage tester by the handles designed for this purpose. Never touch the device beyond the handle ends. Hold the two test tips onto the measuring points to be tested. Press the two push-buttons and simultaneously.

The applied voltage is shown on the LCD display. The Low-Imp LED signals low impedance measurement.

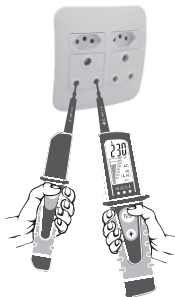

 The maximum permitted duty cycle in low impedance operating mode is 5 seconds for voltages up to 250V and 3 seconds for voltages up to 690V. When this time has lapsed, wait for 10 minutes

### 9. ROTATING FIELD DIRECTION DISPLAY

The voltage tester can show the direction of the rotating field with three-phase systems. Hold the voltage tester by the handles and provided. Never touch the device beyond the handle ends. Hold the two test tips onto the measuring points to be tested. Test tip corresponds to L1, and test tip corresponds to L2. The applied voltage and the rotating field direction is shown on the LCD display. The rotating field direction symbols (D) show the corresponding rotating field direction (L = anticlockwise/ R = clockwise).

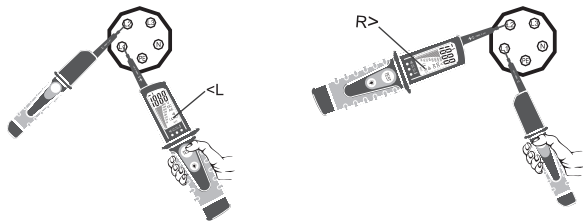

## 10. CONTINUITY CHECK

The voltage tester can also be used as a continuity tester. Always hold the voltage tester by the handles designed for this purpose. Never touch the device beyond the handle ends. The continuity tester switches itself on automatically when the test starts, and switches itself back off when the test has been completed. Check for correct functioning before beginning the test. If you connect the two test tips with each other, you should hear a beep, and the continuity LED should light up. If this is not the case, replace the batteries as described under "Inserting/Changing the Batteries". The continuity tester indicates resistances of up to <math>400\text{ k Ohm}</math>.

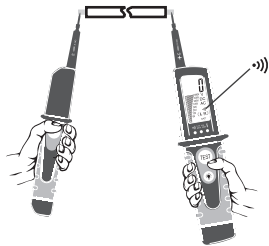

## 11. USING THE VOLTAGE TESTER AS A " SINGLE-POLE" PHASE TESTER

The Voltage tester can also be used as a "single-pole" phase tester. Always hold the voltage tester by the handles designed for this purpose (3 and 6). Never touch the device beyond the handle ends.

⚠ This "phase test" serves as a quick test only. Please check again for zero potential with the twin-pole measuring method before you do any work on this circuit. Observe the regulations regarding work with electrical systems.

Before beginning the test, check the condition of the batteries by connecting the two test tips with each other.

Check for correct functioning at a known alternating voltage source.

Contact test tip "L2" with the measuring point to be tested. In the event of the phase (alternating current between 100 and 690V), the lightning symbol LED lights up.

⚠ The "single-pole" phase display can be adversely affected by unfavourable ambient conditions (electrostatic fields, good insulation etc.). In all cases, conduct an additional, twin-pole voltage test.

## 12. MAINTENANCE AND DISPOSAL

Check the technical safety of the voltage tester regularly. It can be assumed that risk-free operation is no longer possible if:

- there is visible evidence that the device has been damaged
- the device has been stored under unfavorable conditions for a longer period of time
- the device has been subjected to heavy transport strain.

The outside of the device should be cleaned with a soft, damp cloth or brush only.

Do not use abrasive or chemical cleaning agents which could damage the housing or impair operation.

**Never try to open the housing, apart from the battery compartment.**



When the device has become unusable, dispose of it in accordance with the current statutory regulations.

## 13. DISPOSAL OF BATTERIES AND RECHARGEABLE BATTERIES

You, as the end user, are required by law (Battery Ordinance) to return all used batteries/rechargeable batteries. Disposing of them in the household



is prohibited!

Batteries/rechargeable batteries containing hazardous substances are marked by the shown symbols. These symbols also indicate that it is prohibited to dispose of them in the household waste. The heavy metals concerned are:

Cd = cadmium, Hg = mercury, Pb = lead. You can return flat batteries/rechargeable batteries free of charge to the collection points in your community, our branches or anywhere else where batteries are sold.

You thus fulfil your statutory obligations and help to protect the environment!







---

***MAJOR TECH (PTY) LTD***

**South Africa**

🌐 [www.major-tech.com](http://www.major-tech.com)

✉ [sales@major-tech.com](mailto:sales@major-tech.com)

**Australia**

🌐 [www.majortech.com.au](http://www.majortech.com.au)

✉ [info@majortech.com.au](mailto:info@majortech.com.au)

